

## HeatingRegulationProcessor HRP22

### HeatingRegulationProcessor HRP22 M

#### Basic function

HeatingRegulationProcessor HRP22/HRP22 M  
Designed for the regulation, control, optimization and monitoring of heating plants with boiler regulation or remote heating plants.

Bus and modem can be connected.

Maximum 2 Heating loop and precontrol is possible.

One-knob operation and a graphic, illuminated display for the input and query of all DDC data.

Extension of the Basic function by means of HRP software menus such as Optimization, Room Correction, Limitation, Stand by, Boiler Regulation, Domestic-hot-water Heater Tank Control , Circulation Pump, Operating Hours Counter, Heat Amounts Counter, Pump Blocking Protection.

In setting the plant macros, the HeatingRegulationProcessor HRP is completely configured, the accompanying HRP software menus are set, the parameters are configured, and the input and output signals are assigned.

The user is guided through the dialog with a plaintext menu system.

Input and query of the data in 4 priority levels can be accessed with code keys.

Week program and annual program. Trend value acquisition and display of important plant values.

8 HeatingRegulationProcessors HRPs are administered by means of the HRP LRP Bus System. Distance of 1000 m.

Communication of all bus participants with each other in the form of queries or the modification of all parameters, integrated constituent part of the HeatingRegulationProcessor HRP.

A direct connection to the BMS with the RS232 interface. For widely separated plants Data transmission for BMS per modem with the public telephone network.

Important messages can also be sent by modem to a cellular telephone (GSM SMS Service).

Unlimited data backup in case of power failure.

- SPS functions with markers, timer and time programs, freely programmable
- 6 analog inputs for active measuring element KP10
- 1 analog input 0..10 V
- 3 binary inputs
- 2 analog outputs 0..10 V
- 6 binary outputs max. 6 (3) A 230 V AC
- Plastic housing fire-resistant, for control panel mounting,
- Mains 230 V AC  $\pm$  10 % 50..60 Hz

The HRP22 M also has an M-bus connection (DIN EN 1434 3) available for the connection of counters with an M-Bus interface. A maximum of four counters can be connected.



**HRP22/HRP22-M HeizungsRegelProzessor****Device description****Technical data**

Inputs and outputs	3 binary inputs BE	Zero-voltage contact two of these are impulse inputs 20 Hz
	6 binary outputs BA	Relay contacts max. 6 (3) A; 230 V AC
	6 analog inputs AE	KP10, active measuring element
	1 analog input AE	0..10 V continuous (remote setpoint setting)
	2 analog outputs AA	0..10 V; 5 mA at 10 V
	analog/digital conversion	10 Bit
Interfaces	Serial RS232, switching possibilities to RS485	Building Management System BMS, Modem, J-Bus
Bus connection	CAN Bus	Maximum 8 HRP / LRP to one bus system
Nominal voltage	230 V AC $\pm$ 10 %; 50..60 Hz;	
Nominal power	18VA; current requirements 78 mA at 230 V AC	
Displays	Graphics display with backlighting, LED for error messages and manual operation	
diagnosis jack	Diagnosis/ data backup	
Operation	One-knob operation rotating knob, selection button [SET], backstep button [ESC]	
Fuse	Fuse S1 6, (T) for external switching Fuse S2 630 mA (T) for electronics Accessible from the rear	
Processor	80C592	
Memory	64 kByte RAM; 512 kByte Flash PROM	
Operating system	Multitasking	
Mains failure data backup	Lithium battery, unlimited	
Mode of enclosure protection	IP20	
Environmental temperature	0..45°C	
Environmental humidity	In service: 20 – 80 % rF, non-condensing Out of service 5 – 90 % rF, non-condensing	
Housing	Plastic housing fire-resistant	
Measurements	W/H/D: 110.0 mm x 198.5 mm x 77.5 mm (with wall console W/HRP 15.0 mm deeper)	
Front panel cutout	200.4 mm x 112.0 mm	
Weight	1.2 kg	
Identifier	CE	

**Temperature ranges:**

Please note the sensor ranges of the HRP when dealing with the **trend curves and the outside temperature assignment**.

**For temperatures outside these limits, the value is represented as " " (invalid)!**

Par.No.(P90) Techn. address	Par. Name	Lower limit	Upper limit	Base value	Units
b1	outside	<b>50.0</b>	<b>70.0</b>	curr. val. (KP10)	°C
b2	room	<b>0.0</b>	<b>120.0</b>	curr. val. (KP10)	°C
b3	feed	<b>0.0</b>	<b>120.0</b>	curr. val. (KP10)	°C
b4	sensor 4	<b>0.0</b>	<b>120.0</b>	curr. val. (KP10)	°C
b5	sensor 5	<b>0.0</b>	<b>120.0</b>	curr. val. (KP10)	°C
b6	sensor 6	<b>0.0</b>	<b>120.0</b>	curr. val. (KP10)	°C
b7	Sensor 7	<b>0.0</b>	<b>100.0</b>	curr. val. (0 10V)	% *1)

\*1) b7 are scalable between -1000.0 and +1000.0.

Wiring diagram

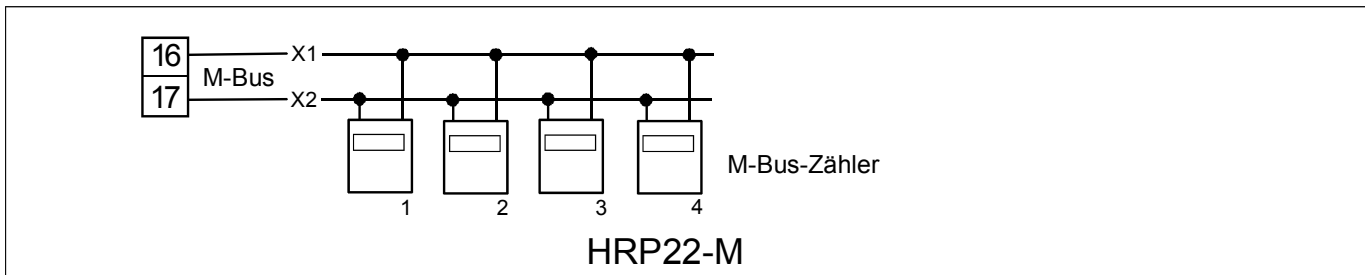
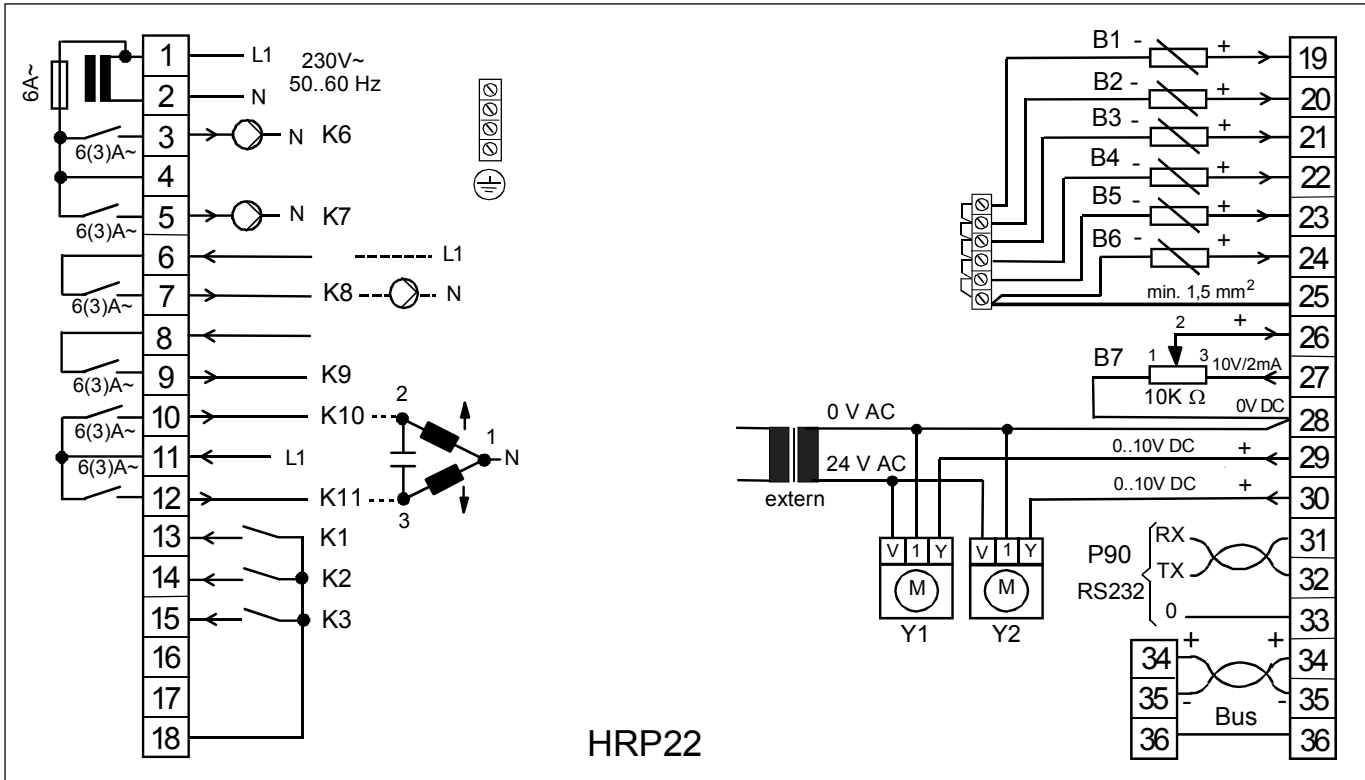

## Device description

## HRP22/HRP22-M HeizungsRegelProzessor

## Related software menus

Menu	No.	How often occurs	Comments
Basic menu (heating)		2x	Weather-oriented feed temperature regulation, switchable to fixed value regulation
Extensive control functions		1x	Free parameterization of the contact outputs – 16 markers – 8 timers
Remote control	12	2x	Effects basic menu 1
Operating hours	18	2x	
Impulse counting	19	2x	Effective with the contact inputs K2 and K3 (including power calculations)
Min/Max/Middle	20	2x	
Limit values	23	8x	
Scaling	25	1x	Scaling possibility for the input 0 10V (B7). Scaling is carried out by addressing the sensor
Usage time	26	3x	Per usage time, four switching times are available, furthermore, four special usage times which effect the first usage time
Vacation periods	27	1x	
Modem	28	1x	
SMS	29	1x	
Minitel	30	1x	
J-Bus	31	1x	
Room correction	41	1x	
Stand by	42	1x	
Optimization	43	1x	
Boiler regulation	46	1x	For potable water heating
Chimneysweep	49	1x	Effect in connection with the software menu boiler regulating
Legionnaire	50	1x	Effect in connection with the software menu boiler regulating
Remote control	51	2x	
Plant messages	52	8x	
Double pumps	53	1x	Effect in connection with basic menu 1 heating

Date 26.02.2004

Menu	No.	How often occurs	Comments
Boiler regulation	61	1x	
Precontrol	62	1x	
Circulation	63	1x	
Three-point operation	64	2x	
Limitation	65	2x	
M-Bus	67	4x	Effective only at HRP22 M
Remote bus		1x	Effective only at HRP22 M