

VentilationRegulatorProcessor LRP4



Basic function

VentilationRegulatorProcessor LRP. For the regulation, control, and monitoring of ventilation plants with PID regulation. Bus and modem can be connected.

One-knob operation and a graphic, illuminated display for the input and query of all LRP data.

Extension of the basic function by means of LRP software menus like cascade control, start circuit, Y-Set, Y-Limitation, actual value sliding, actual value correction, energy selection, continuous frost protection, operating hours counter, heat amount counter, limit values.

In setting the plant macros, the VentilationRegulatorProcessor LRP is completely configured, the accompanying LRP software menus are set, the parameters are configured, and the input and output signals are assigned.

The user is guided through the dialog with a plaintext menu system. input and query of the data in four priority levels by means of a code key.

Week and annual program. Trend values acquisition and the display of important plant data.

Eight ventilationRegelProcessors LRPs are administered with the LRP Bus System. Maximum distance of 1000 m. Communication of all bus participants among each other with queries or modifying all parameters, integrated constituent part of the ventilationRegulationProcessor LRP.

A direct connection to the BMS with the RS232 interface. For plants spatially far apart from each other. Data transmission for BMS per modem with the public telephone network. Important messages can also be sent by modem to the mobile telephone system D2 (GSM SMS Service).

Unlimited data backup in case of power failure.

- SPS functions with marker, timer and time programs, freely programmable.
- 5 analog inputs for temperature sensor with measuring element KP10 ,
- 3 analog inputs for 0..10 V,
- 8 binary inputs
- 4 analog outputs 0..10 V
- 4 binary outputs 24 V AC; 6 (3) A for ventilator and pump control
- Plastic housing fire-resistant, for control panel mounting
- Mains 24 V AC +/- 10 %; 50..60 Hz,

Technical data

Bus connection	CAN Bus	Maximum 8 HRP / LRP to one bus system
Interfaces	Serial RS232	Building Management System BMS, Modem
	Diagnosis jack	Diagnosis, data backup
Inputs and outputs	8 binary inputs BE	Zero-voltage contact
	4 binary outputs BA	Relay contacts max. 6(3)A; 24V AC
	5 analog inputs AE	KP10, active measuring element
	3 analog inputs AE	1x 0..10 V continuous
	4 analog outputs AA	0..10 V continuous; max. 5mA
Operating voltage	24 V AC \pm 10 %; 50..60 Hz; 12 VA; 450 mA at 24 V AC	
Fuse	Fuse 630mA for electronics	
Address switch	Settings per parametrization	
Displays	Graphics display with backlighting, LED for manual operation and error messages	
Switch, buttons	One-knob operation rotating knob, selection button [SET], backstep key [ESC]	
Processor	80C592	
Memory	64 kByte RAM; 512 kByte Flash PROM	
Operating system	Multitasking	
Mains loss, data backup	Lithium battery, unlimited	
Mode of enclosure protection	IP20	
Environmental temperature	0..45°C	
Environmental humidity	In service:	20 80 % rF, non-condensing
	Out of service	5 90 % rF, non-condensing
Housing	Plastic housing fire-resistant B x H x T; 110.0 mm x 199.0 mm x 85.0 mm (with wall console W/HRP 92.5 mm deep)	
Front panel cutout	200.4 mm x 112.0 mm	
Weight	1.0 kg	
Identifier	CE	

Devise description

LüftungsRegelProcessor LRP4

Temperature ranges of the LRP4:

Please note the **trend curves and the temperature assignments** the sensor ranges of the LRP.
For temperatures outside these ranges, the value is given as " " (invalid)!

Par.No.(P90) Techn. address	Par. Name	Lower limit	Upper limit	Base value	Units
b1	outside	50.0	70.0	curr. val. (KP10)	°C
b2	sensor 1	50.0	70.0	curr. val. (KP10)	°C
b3	sensor 2	50.0	70.0	curr. val. (KP10)	°C
b4	sensor 3	0.0	120.0	curr. val. (KP10)	°C
b5	sensor 3	0.0	120.0	curr. val. (KP10)	°C
b6	sensor 4	0.0	100.0	curr. val. (0 10V)	% *1)
b7	sensor 7	0.0	100.0	curr. val. (0 10V)	% *1)
b8	remote control	0.0	100.0	curr. val. (0 10V)	% *1)

*1) b6 – b8 are scalable between –1000.0 and +1000.0.

Wiring diagram

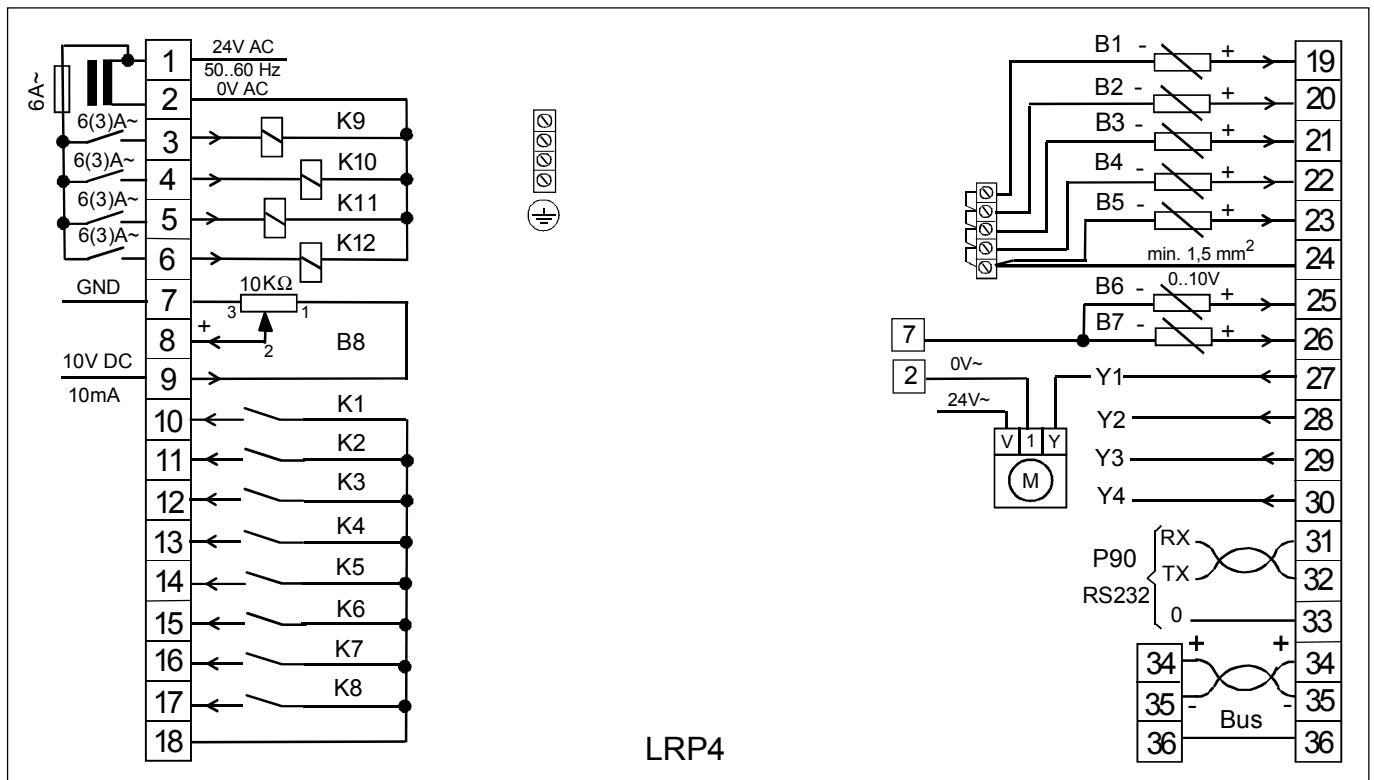

Ausgabe 10.10.2000

Related software menus

Menu	No.	How often occurs	Comments
Basic menu ventilation		1x	Ventilation control loop with 4 sequences PID regulator
Cascade	2	1x	Effects basic menu
SW switching	3	1x	Effects basic menu
Free night cooling	4	1x	Effects basic menu
Optimization/heating-up	5	1x	Effects basic menu
Start circuit	6	1x	Effects basic menu
Y-Limitation	7	2x	
Actual value sliding	8	1x	Effects basic menu
Energy selection	9	1x	
Cont. frost protection	10	1x	
Frost protection pump	11	1x	
SW remote control	12	1x	
Actual value correction	13	1x	Effects basic menu
Standstill regulation	14	1x	Effects basic menu
Y-Set	15	2x	
Fixed value	16	1x	
Sequence reversal	17	1x	
Operating hours 2	18	2x	
Heat amounts counter	19	2x	
Min/Max/Middle	20	1x	
Pump blocking protection	21	1x	
Mixed air control	22	1x	
Limit values	23	8X	
Sequence menu	24	1x	
Scaling 1	25	3x	Scaling possibility for the 0 10 V inputs (B6, B7, B8)
Usage time	26	2x	Per usage time, four switching times are available. Furthermore, four special usage times which effect the first usage time
Holidays	27	1x	
Modem	28	1x	
SMS	29	1x	
Minitel	30	1x	
J-Bus	31	1x	