

The DDC central technolon® DDC3550-L is an autonomous DDC central for regulating, optimising, controlling and monitoring functions with LON bus interface.



## Function

- The DDC central technolon® DDC3550-L contains 12 DDC heating or ventilation control circuits with a vast library of DDC software menus, SPS functions with 499 markers, 99 timers and time programs.
- Up to 99 DDC centrals can be linked via a bi-directional data bus, with permanent system monitoring of the bus communication.
- DDC3550-L contains a fault message storage, an event log with date, time and an automatic summer/winter time change-over.
- A user-guided plaintext dialog allows the enquiry and input of DDC data as actual values, set values and durations.
- The entire DDC system can be fully operated from every linked DDC central (Remote Control) without any additional device.
- The LON bus interface is a FT10 transceiver or alternatively a TP1250 transceiver.
- Customised plaintext is possible for every parameter.
- The allocation of the DDC parameters to LON standard network variables is effected via plug-in.
- The plug-in can be downloaded at [www.kieback-peter.de](http://www.kieback-peter.de) - Open Communication - LON.
- Max. 1,023 DDC parameters can be allocated.
- The LON bus interface (L-Core) manages 1.,023 address list entries, 4.096 alias network variables and 256 group entries.

**Technical Data**

Bus link	LON bus	FT10 transceiver, alternatively TP1250 transceiver
	Central bus (Z Bus)	for 99 1,000 m (3,000 m with drivers), 100 kBaud DDCSOOO centrals
	Field bus (F-Bus)	2,000 m, 20 kBaud, CAN for 63 field bus modules FBM/FieldBusController FBR
	Switch cabinet bus (SBM-Bus)	200 m, 40 kBaud, CAN for 16 switch cabinet bus modules SBM
Service voltage	for DDC central	24 V AC ±10 %, 50..60 Hz, 800 mA, 19.2 VA at nominal voltage
	for LON module	12 V DC ±10 % / 800 mA
	for field bus modules FBM	12 V DC ±25 % / 50 mA
Fuses	Network	T 0.63 A
	Communication server	T 1.0 A
Address switch	00..99	Address-setup 01..99 with 2 rotary switches behind the front cover
Displays	LCD Display	4 x 20 digits, illuminated
	LED Data	blinking during data transfer F-Bus and SBM-Bus
	LED Error	illuminated during Z-bus fault or empty battery
	LED P90 (Geräterückseite)	blinkt bei Buskommunikation P90 – LON
	Service-LED (backside of device)(	signals the current status of the LON knot through various blinking patterns, see paragraph Service LED
	LED L-Core (backside of device, behind the mounting plate)	shows the status of the LON module in three colours, see paragraph LED L-Core
switches/ keys	30 keys	
	1 Service PIN (backside of device)	sends a 48 bit serial number (Neuron-Chip-Id) to all knot within the network while being pressed. Necessary for the commissioning process. approx. 10 years, clock with buffer battery
Data security	in case of network failure	
Housing	19" short cassette	quadruple plastic cassette with two plug in sockets, width x height x depth: 202 x 132 x 148 mm
Ambient conditions	Temperature Humidity	0..45 °C 20..80 % rF, not condensing
Protective system	IP40	
Installation	Switchboard front installation or Switchboard front installation	Switch board cutout: 200.4 x 112.0 mm  with 19" rackside KA
Weight	1.1 kg	
Identification	CE	
	LonMark	certified

Connecting plan DDC3550-L

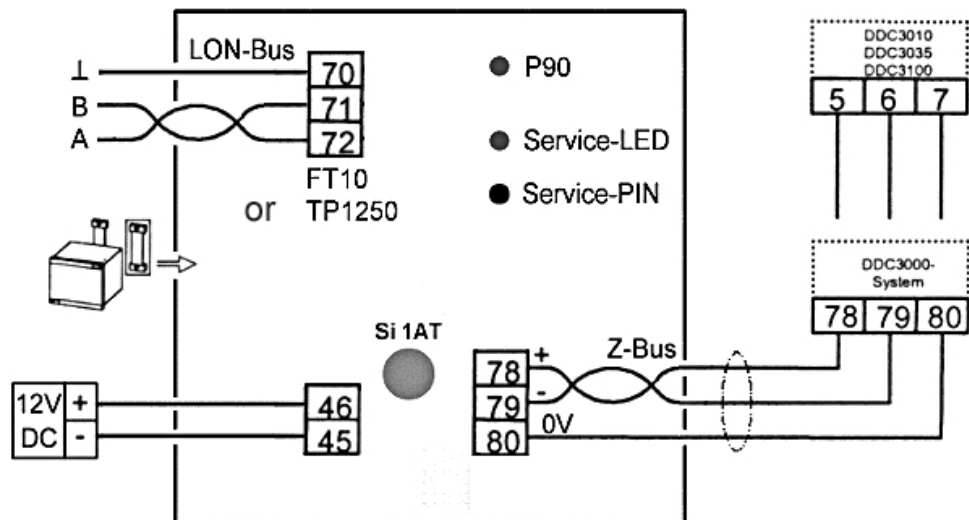
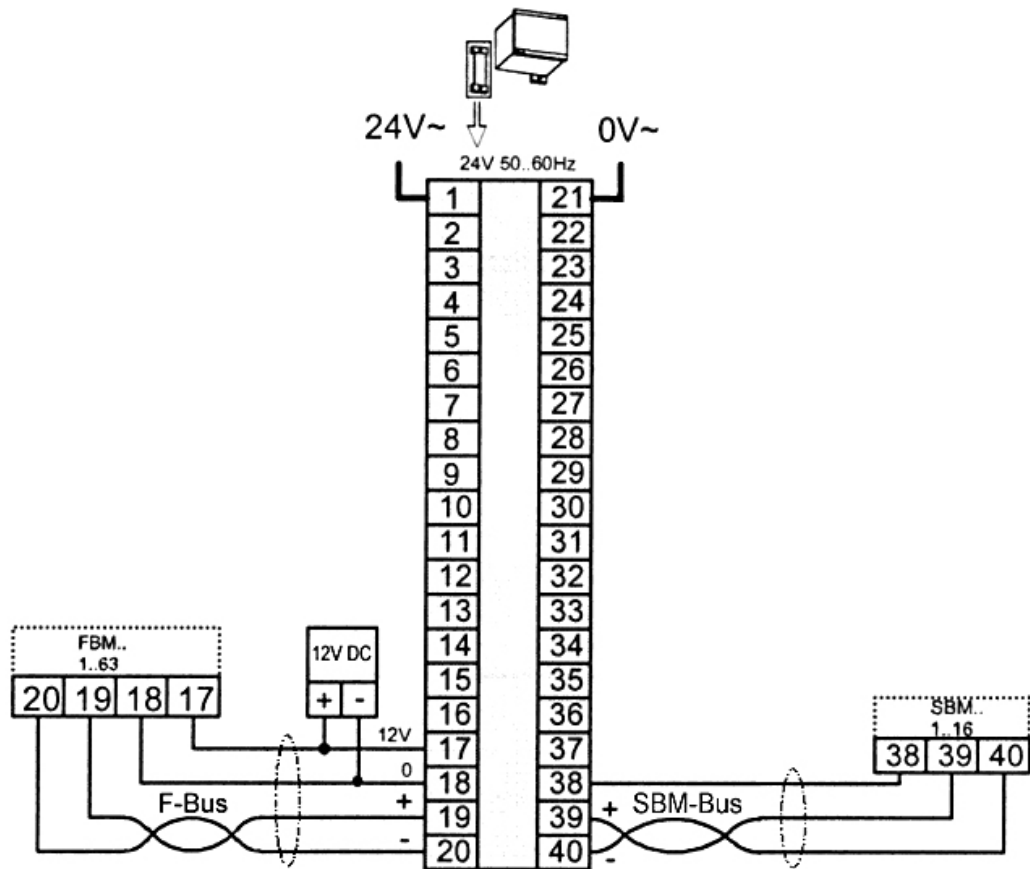

**Service LED**

The Service LED signals the current status of the LON knot through various blinking patterns.

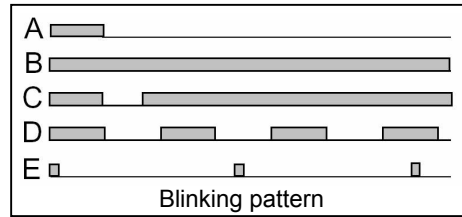

Meaning of the blinking patterns:

**A NORMAL OPERATION**

When starting the device, the Service LED flashes for approx. 5 seconds and then extinguishes. The L-Core is configured and working correctly. Furthermore, the Service LED is always illuminated with the Service PIN being pressed.

**B FATAL ERROR**

The L-Core was not able to start (Clock, CPU bus, reset or firmware fault)

**C APPLICATIONLESS**

The L-Core cannot start in mode "APPLICATIONLESS". The knot was set to this state by an external tool (e.g. Node util). The application is still existing. The knot being reset to "configured online", it continues to work normally.

**D UNCONFIGURED**

With an unconfigured knot the Service LED blinks at a frequency of 1 Hz. The application is working, however the knot has no logic network address. The knot needs configuration (allocation of a logic address by commissioning).

**E WATCHDOG-Funktion**

The internal Watchdog of the L-Core restarts the L-Chip every 5 ms. The LON knot wants to start, but detects a runtime error. The cause of this fault can be non-functioning parallel ports or unsynchronised bit-serial interfaces. (e.g. no GO exchange via RS232 (P90)).

**LED L-Core**

The LED LON behind the mounting plate at the backside of the device shows the operation status of the LON module in three colours.

- LED shines green      Normal operation  
The L-Core has configuration data and an allocation list (application).  
The data exchange via the internal P90 interface is working impeccably.
- LED shines red        Error flag  
The L-Core has neither configuration data nor an allocation list (application).
- LED shines orange    Error flag  
Usually the P90 communication (P90 - LON) is interrupted.

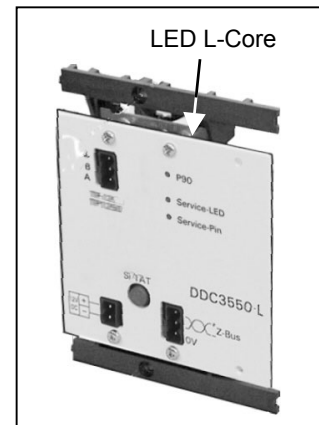

This can have the following causes:

1. An invalid P90 address was used in the allocation list. Even a wrong syntax (e.g. s1 instead of S01) can lead to this error. The project shall be error-checked. These errors can be found in the plug-in protocol, protocol call-in: press button "Protocol" in the plug-in. The plug-in can be downloaded at [www.kieback-peter.de](http://www.kieback-peter.de) / Open Communication / LON.
2. A new firmware will be loaded in the L-Core module or in the DDC central. In both cases the P90 communication will be set temporarily.
3. The DDC3550-L "functional block" (blue box in the LonMaker project) was set to 'disable' (LonMaker->Manage->List FBs->Disable). This interrupts the P90 communication until the "functional block" is reset to 'enable'.